

KIPOR

KIPOR POWER OPERATION MANUAL

PLEASE READ THIS MANUAL CAREFULLY.
IT CONTAINS IMPORTANT SAFETY INFORMATION.

WWW.KIPOR.COM

KIPOR

KIPOR POWER CO., LTD.

11/F Suntime International Mansion, 450 Fushan Road,
Pudong, Shanghai, China
TEL: 86-21-58208881
FAX: 86-21-58208877
E-MAIL: kipor@wxkipor.com

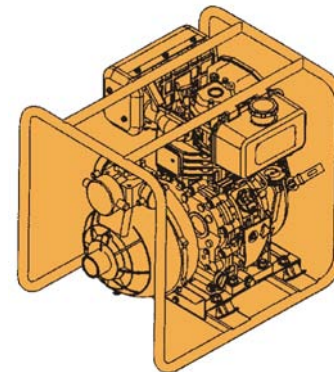

**HIGH PRESSURE
DIESEL PUMP**

KDP15H

Version 1, Printing date 03/06/2004

PREFACE

Thank you for purchasing a KIPOR water pump.

This manual covers the operation and maintenance of KIPOR high-pressure water pump: KDP15H.

All information in this publication is based on the latest product information available at the time of approval for printing.

KIPOR reserves the right to make changes at any time without notice and without incurring any obligation.

No part of this publication may be reproduced without written permission.

This manual should be considered a permanent part of the pump and should remain with the pump if it is resold.

Pay special attention to statements preceded by the following words



Indicates a strong possibility of severe personal injury or death if instructions are not followed.



Indicates a possibility of equipment or property damage if instructions are not followed.



Gives helpful information.

If a problem should arise, or if you have any questions about the pump, consult an authorized KIPOR dealer.



KIPOR water pump is designed to give safe and dependable service if operated according to instructions.

Read and understand the Owner's Manual before operating the water pump. Failure to do so could result in personal injury or equipment damage.

CONTENTS

1.SAFETY INSTRUCTION	1
2.SAFETY LABEL LOCATIONS	2
3.COMPONENT IDENTIFICATION	4
4.PRE-OPERATION CHECK	5
5.STARTING THE ENGINE	10
6.OPERATION	12
7.STOPPING THE ENGINE	13
8.MAINTENANCE	14
9.TRANSPORTING/STORAGE	18
10.TROUBLESHOOTING	20
11.SPECIFICATIONS.....	21

11. SPECIFICATION

MODEL	KDP15H
Inlet outlet diameter [(mm)in]	40 (1.6 ")
Rated flow (m ³ /h)	5
Rated lift head [m(ft)]	42 (137)
Max. lift head [m(ft)]	8 (26)
Self-priming time (4m) (s)	40
Dry weight [kg (lbs)]	46 (101)
Overall dimension (L×W×H) [mm(in)]	570×445×550 (22.4×17.5×21.6)
Engine model	KM178
Engine Type	Single cylinder, 4-stroke, direct injection, vertical
Displacement [cm ³ (cu in)]	296 (11.96)
Bore × Stroke [mm(in)]	78×62 (3.1×2.4)
Max. output [kW(HP)/rpm]	4.4 (6.0)/3600
Cooling system	Forced air
PTO shaft rotation direction	Counterclockwise

10. TROUBLESHOOTING

When the engine will not start:

1. Is the diesel oil used appropriate?
2. Is there enough oil in the engine?
3. Is the fuel valve ON?
4. Is there fuel in the fuel tank?
5. Is the injection timing correct?
Adjust the thickness of the shim packs.
6. Is the atomization of the injection nozzle bad?
Clean or replace the injection nozzle.
7. If the engine still does not start, take the pump to an authorized KIPOR dealer.

WARNING If any fuel is spilled, make sure the area is dry before starting the engine. Spilled fuel or fuel vapor may ignite.

When the pump cannot pump the water:

1. Is the pump fully primed?

PRIMING WATER
FILLER CAP

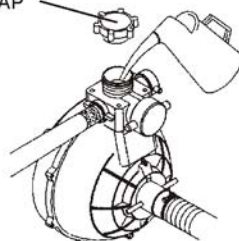

2. Is the strainer clogged?
3. Are the hose bands installed securely?
4. Is the hose damaged?
5. Is the suction head too high?
6. If the pump still does not operate, take the pump to an authorized KIPOR dealer.

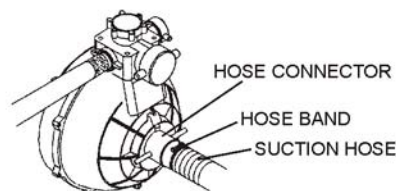
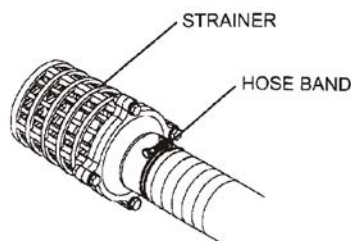

1. SAFETY INSTRUCTION

To ensure safe operation-



- KIPOR water pump is designed to give safe and dependable service if operated according to instructions. Read and understand the Owner's Manual before operating the water pump. Failure to do so could result in personal injury or equipment damage.
 - The muffler becomes very hot during operation and remains hot for a while after stopping the engine. Be careful not to touch the muffler while it is hot. Let the engine cool before storing the water pump indoors.
 - The engine exhaust system will be heated during operation and remain hot immediately after stopping the engine. To prevent scalding, pay attention to the warning marks attached to the water pump.
 - Always make a pre-operation inspection before you start the engine. You may prevent an accident or equipment damage.
 - For safety, never pump flammable or corrosive liquids such as gasoline oil or acid. Also, to avoid pump corrosion, never pump seawater, chemical solution, or caustic liquids such as used oil, wine, or milk.
 - Place the pump on a firm, level surface lesting the pump overturn.
 - To prevent fire hazards and to provide adequate ventilation, keep the pump at least 1 meter away from building walls and other equipment during operation. Do not place flammable objects close the pump.
 - Children and pets must be kept away from the area of operation to reduce a possibility of burns from the hot engine components.
 - Know how to stop the pump quickly, and understand the operation all the controls. Never permit anyone to operate the pump without the proper instructions.
- WARNING** To ensure safe operation —
- Diesel oil is extremely flammable and explosive under certain conditions.
 - Refuel in a well-ventilated area with the engine stopped. Do not smoke or allow flames or sparks in the refueling area or where diesel oil is stored.
 - Do not overfill the tank (there should be no fuel above the upper limit mark). After refueling, make sure the tank cap is closed properly and securely.
 - Be careful not to spill fuel when refueling. Spilled fuel and fuel vapor may ignite. If any fuel is spilled, make sure the area is dry before starting the engine.
 - Never run the engine in an enclosed or confined area. Exhaust gas contains poisonous carbon monoxide gas; exposure can cause loss of consciousness and may lead to death.

2.SAFETY LABEL LOCATIONS

These labels warn you of potential hazards that can cause serious injury. Read the labels and safety notes and precautions described in this manual carefully.

If a label comes off or becomes hard to read, contact your KIPOR dealer for a replacement.

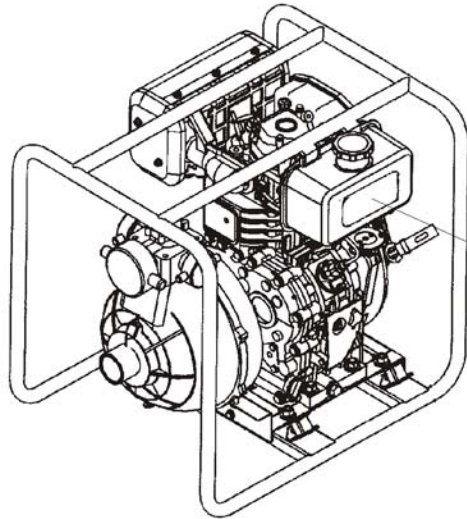

Read the manual

3. Drain the fuel
 - a. Drain the diesel oil in the fuel tank into the suitable container tipping the pump slightly lest the control part should not be contaminated by the drained diesel oil.
 - b. Retighten the fuel valve again.

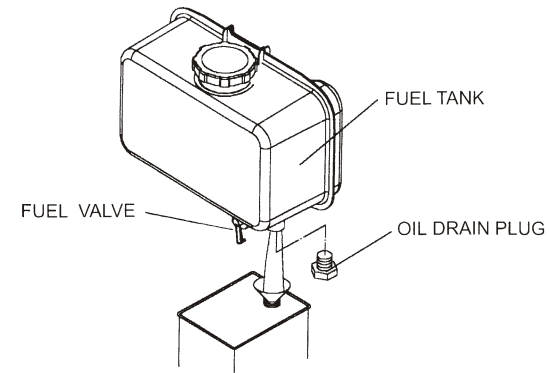

4. Replace the engine oil.
5. Clean the air cleaner.
6. Pull the starter grip until resistance is felt. This will close the valves so moisture cannot enter the engine cylinder, and protect the engine from dust and corrosion. Return the starter grip gently.
7. Cover the pump to keep out dust.

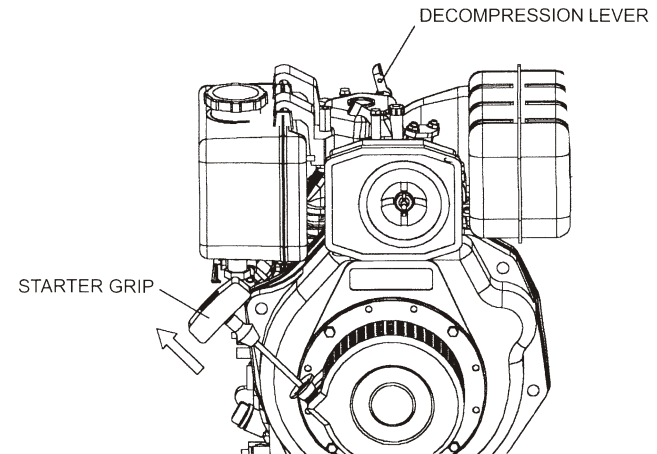

9. TRANSPORTING/STORAGE

WARNING

- To avoid severe burns or fire hazards, let the engine cool before transporting the pump or storing it indoors.
- When transporting the pump, turn the fuel valve to the OFF position, keep the pump level and make sure the tank cap is installed securely. Spilled fuel or fuel vapor may ignite.

Before storing the pump for an extended period.

1. Be sure the storage area is free of excessive humidity and dust.
2. Clean the pump interior.

Sediment will settle in the pump if it has been used in muddy, sandy water or water containing heavy debris.

Pump clean water through the pump before shutting down, or impeller may be damaged when restarting. After flushing, remove the pump drain plug, drain as much water as possible from the pump housing and reinstall the plug.

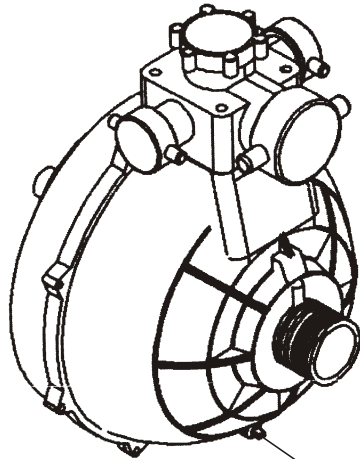

PUMP DRAIN PLUG

NAMEPLATE LOCATION

KIPOR KDP15H HIGH PRESSURE DIESEL PUMP		
Bore x Stroke	78x62	mm
Inlet, Outlet Diameter	40	mm
Rated Flow	5	m ³ /h
Rated Lift Head	42	m
Max Lift Head	8	m

KIPOR POWER CO., LTD.

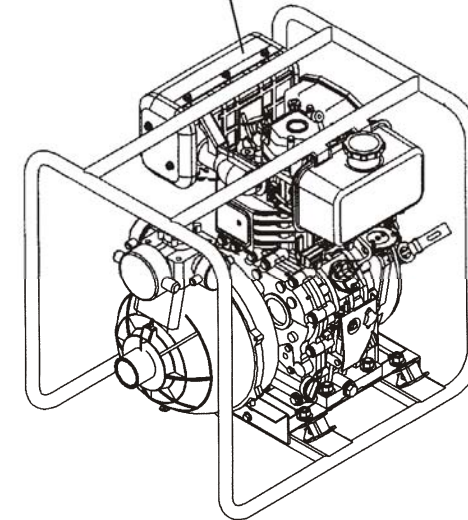

3.COMPONENT IDENTIFICATION

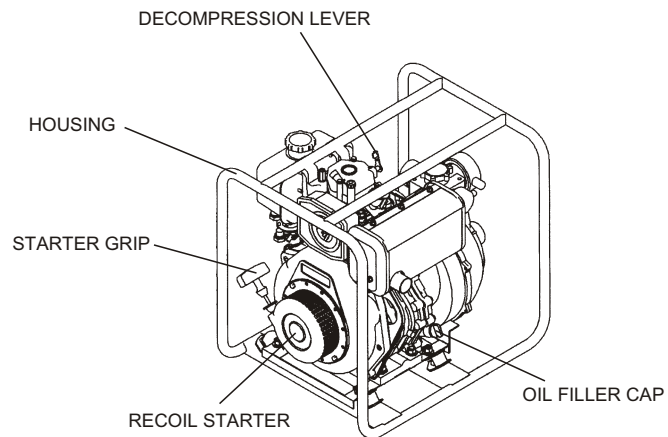
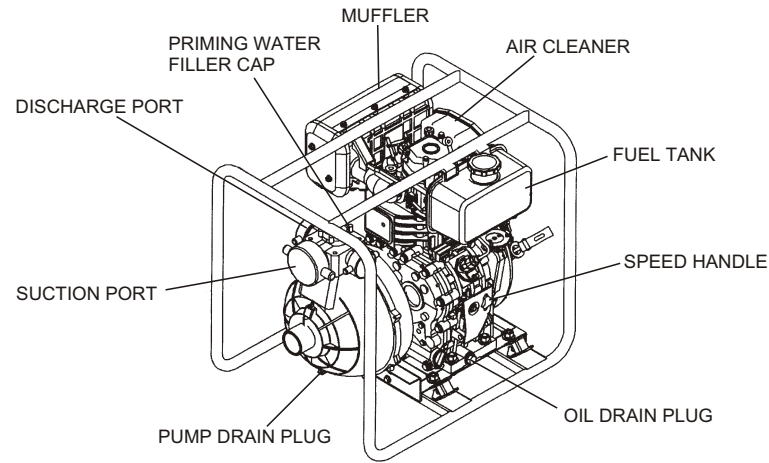

- (1). Remove the air cleaner cover by loosening the wing nut.
- (2). Wash the element in a nonflammable or high flash point solvent and dry it thoroughly.
- (3). Soak the element in clean engine oil and squeeze out the excess oil.
- (4). Reinstall the air cleaner element.
- (5). Reinstall the air cleaner cover, then screw on the wing nut and tighten it securely.

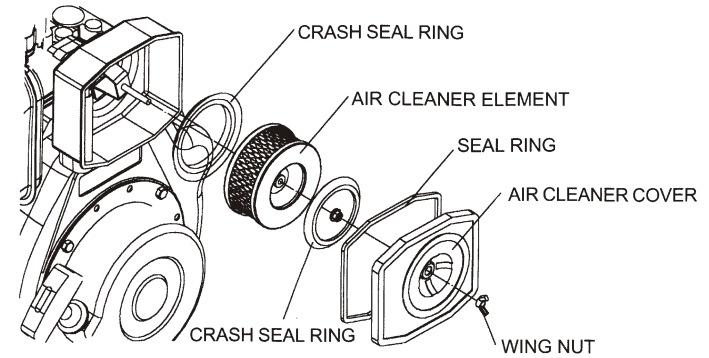

3.Cleaning and replacing the fuel filter.

Remove the fuel filter from the fuel tank, then wash or replace it.

Clean: every 6 months or 500 hours.

Replace: every year or 1000 hours.

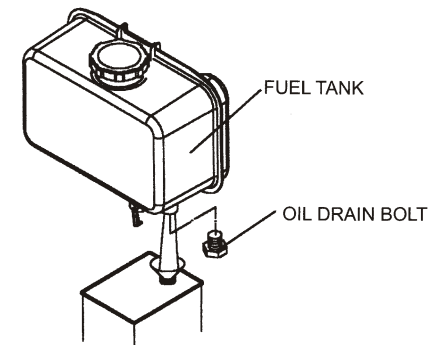

- (1). Drain the fuel from the fuel tank thoroughly.
- (2). Screw off two nuts in the fuel valve, remove the fuel filter from the fuel tank.



WARNING

If the engine has been running, the muffler will be very hot. Allow it to cool before proceeding.

1. Change oil

Drain the oil while the engine is still warm to assure rapid and complete draining.

- (1). Remove the oil filler cap and drain plug to drain the oil.
- (2). Install the drain plug, and tighten it securely.
- (3). Refill with the recommended oil and check the oil level.
- (4). Install the oil filler cap.

Engine oil capacity: **1.1L (0.29US. gal)**

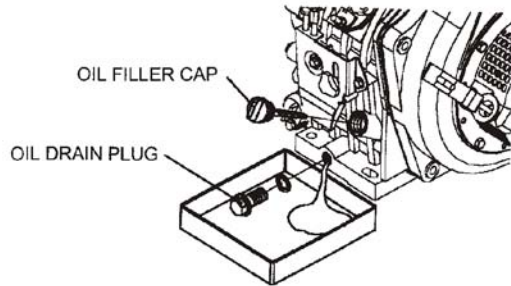

Wash your hands with soap and water after handling used oil.

NOTE

Please dispose of used engine oil in a manner that is compatible with the environment. We suggest you take it in a sealed container to your local service station for reclamation. Do not throw in the trash or pour it on the ground.

2. Air cleaner service

A dirty air cleaner element will restrict the air flowing, resulting in hard starting, loss of output and the exhaust of black smoke. To prevent pump malfunction, service the cleaner regularly. Service more frequently when operating the pump in extremely dusty areas.

WARNING

Do not use diesel oil or low flash point solvents for cleaning. They are flammable and explosive under certain conditions.

CAUTION

Never run the pump without the air cleaner. Rapid engine wear will result from contaminants such as dust and dirt being drawn into the engine.

4. PRE-OPERATION CHECK

1. Install the hose connector.

Be sure to check that the packing is seated in its place and install the hose connector to the port on the pump.

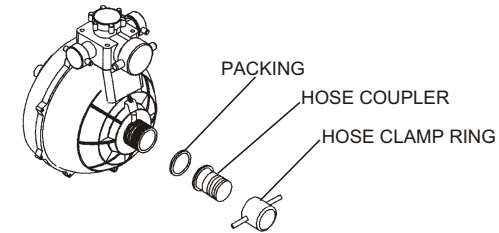

2. Connect the suction hose.

Use commercially available hose, hose connector and hose band. The suction hose must be of reinforced, noncollapsible construction. Suction hose length should not be longer than necessary, as pump performance is best when the pump is not far above the water level. Self-priming time is also proportional to hose length.

The strainer that is provided with the pump should be attached to the end of the suction hose with a band, as shown.

CAUTION

Always install the strainer on the end of the suction hose before pumping. The strainer will exclude debris that can cause clogging or impeller damage.

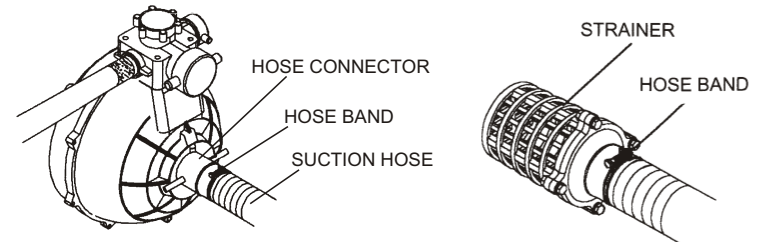

3. Connect the discharge hose

Use a commercially available hose, hose connector and hose band. A short, large-diameter hose is most efficient. Long or small-diameter hose increases fluid friction and reduces pump output.

NOTE

Tighten the hose band securely to prevent the hose from disconnecting under high pressure.

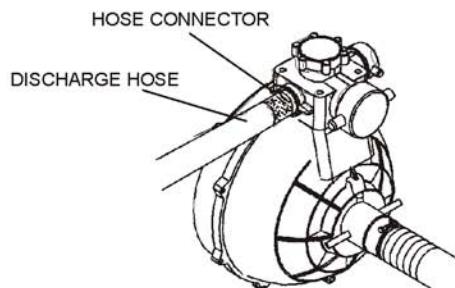

4. Check the engine oil level.

Every 10 hours, check the engine oil level and replenish oil up to the top of the oil filler neck if the pump is operated for more than 10 hours continuously.

CAUTION

- Engine oil is a major factor affecting engine performance and service life. Nondetergent or vegetable oil is not recommended.
- Be sure to check the engine oil on a level surface with the engine stopped.

Use KIPOR 4-stroke oil; or an equivalent high detergent premium quality motor oil certified to meet or exceed U.S. automobile manufacturer's requirements for Service Classification SG, SF. (motor oils classified SG, SF will show this designation on the container.) SAE 10W-30 is recommended for general, all temperature use. If single viscosity oil is used, select the appropriate viscosity for the average temperature in your area.

SAE Viscosity Grades

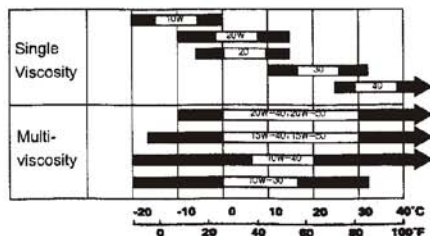

Maintenance schedule

INTERVALS (hours) \ ITEM	Before each use	First month or 20hrs	First year or 50hrs	First year or 100hrs	First year or 200hrs	First year or 500hrs	First year or 1000hrs
All bolts and nuts check	○						
Check and replenish oil	○						
Change lube oil		○ (first)		○ (second)			
Clean oil filter		○					
Check for oil leakage	○						
Air cleaner element replacement					○		
Clean or replace fuel filter				○ (first)		○ (clean)	○ (replace)
Check fuel injection						○	
Check fuel injection pump						○	
Adjust valve clearance of intake and exhaust valve						○	
Check intake and exhaust valve base							○
Replace piston ring							○

NOTE:

- (1) Service more frequently when used in dusty areas.
- (2) Change engine oil every 25 hours when used under heavy load or high ambient temperature.
- (3) These items should be serviced by an authorized KIPOR dealer, unless the owner has the proper tools and is mechanically proficient. See the KIPOR Shop Manual.

8.MAINTENANCE

Periodic inspection and adjustment of the pump are essential if high level performance is to be maintained. Regular maintenance will also help to extend service life. The required service intervals and the kind of maintenance to be performed are described in the table below.

WARNING

- Shut off the engine before performing any maintenance
- If the engine must be run, make sure the area is well-ventilated. The exhaust contains poisonous carbon monoxide gas; exposure can cause loss of consciousness and may lead to death.

CAUTION

- If the pump has been used with seawater, etc., pump clean, fresh water immediately afterward to reduce corrosion or remove sediment.
- Use genuine KIPOR parts or their equivalent for maintenance or repair. Replacement parts which are not equivalent quality may damage the pump.

CAUTION

Using nondetergent oil or 2-stroke engine oil could shorten the engine's service life.

The recommended operating temperature range of this engine is -5 °C to 40 °C (23°F to 104°F)

1. Place the engine horizontally on a level surface.
2. Remove the oil filler cap and check the oil level.
3. If the level is low, fill to the edge of oil filler hole with the recommended oil.

CAUTION

Running the engine with insufficient oil can cause serious engine damage.

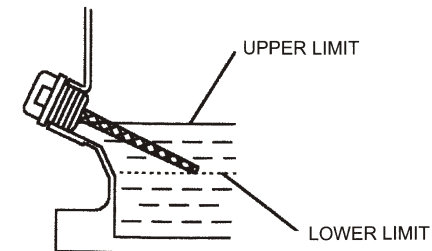
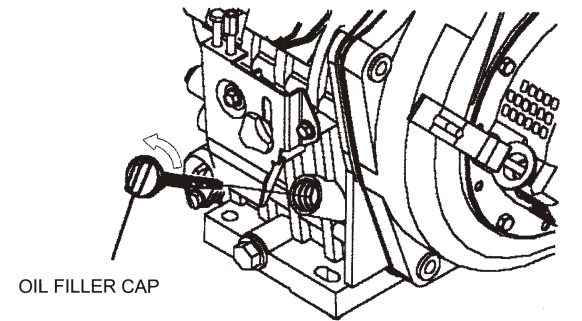

5. Check the fuel level

Remove the fuel tank cap and check the level. Refill the tank if the fuel level is low.

The appropriate fuel for the diesel is 0[#] diesel oil (for summer) and -10[#] diesel oil (for winter). Never use an oil /diesel oil mixture or dirty diesel oil. Avoid getting dirt, dust and water in the fuel tank.

WARNING

- Diesel oil is extremely flammable and is explosive under certain conditions.
- Refuel in a well-ventilated area with the engine stopped. Do not smoke or allow flames or sparks in the refueling area or where diesel oil is stored.
- Do not overfill the tank (there should be no fuel above the upper limit mark). After refueling, make sure the tank cap is closed properly and securely.
- Be careful not to spill fuel when refueling. Spilled fuel or fuel vapor may ignite. If any fuel is spilled, make sure the area is dry before starting the engine.
- Avoid repeated or prolonged contact with skin or breathing of vapor. KEEP OUT OF REACH OF CHILDREN.

Fuel tank capacity: KDP20: 3.5L (0.93US. gal)

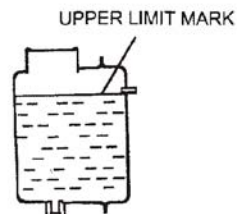
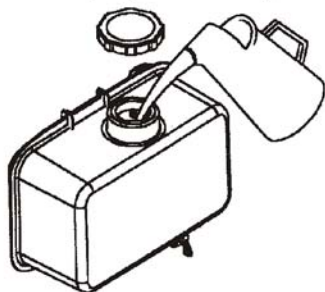

6. Check the air cleaner element.

Remove the air cleaner cover by loosening the wing nut on the top of the air cleaner cover.

Check the element to be sure it is clean and in good condition.

If the element is dirty, clean it. Replace the element if it is damaged.

Reinstall the element and air cleaner cover.

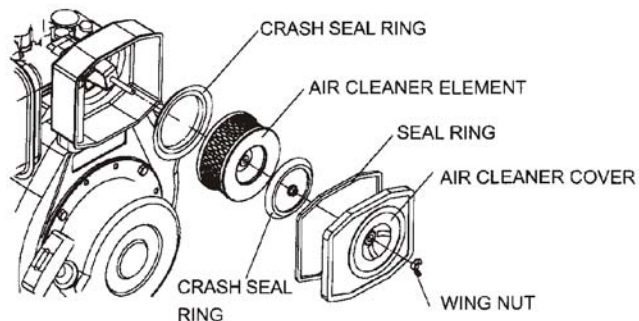

7. STOPPING THE ENGINE

To stop the engine, simply turn the engine switch to the STOP position. Under normal conditions, use the following procedure.

1. Move the governor lever to the STOP position.

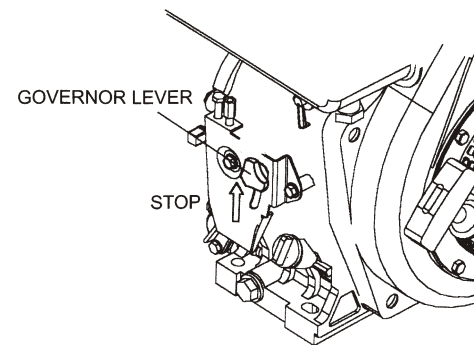

2. Turn the fuel valve in the fuel tank to the OFF position.

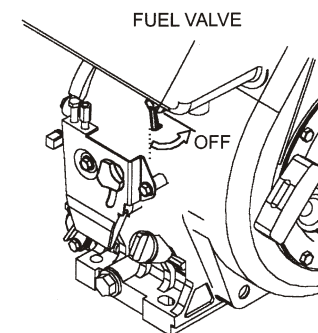

After use, remove the pump drain plug, and the filler cap, flush the pump chamber with clean, fresh water. Allow the water to drain from the chamber, then reinstall the filler cap and drain plug.

6. OPERATION

CAUTION

Never use the pump for muddy water, rejected oil, wine, etc. Do not pull the governor linkage to operate the engine forcibly outside its design parameters.

1. Turn the governor lever to the desired engine speed position.

Discharge flow is controlled by adjusting the engine speed. Moving the governor lever to the FAST position will increase the flow, and the SLOW position will decrease pump flow.

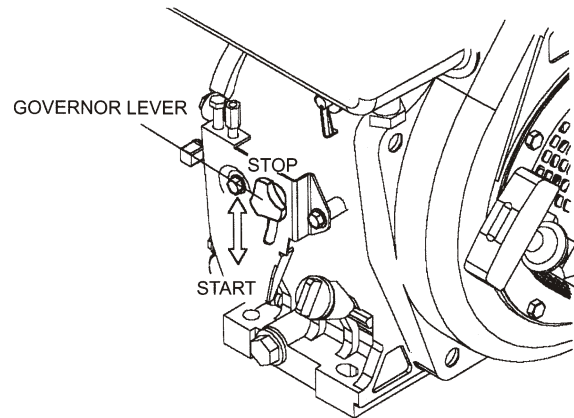

CAUTION

Never run the engine without the air cleaner. Rapid engine wear will result from contaminants, such as dust and dirt, getting into the engine.

7. Check that all nuts, bolts, and screws are tightened.

Tighten the bolts and nuts properly and securely, if necessary.

8. Check the priming water.

The pump chamber should be primed with full of water before operating.

CAUTION

Never attempt to operate the pump without priming water, or the pump will overheat.

Extended dry operation will destroy the pump seal. If the unit has been operated dry, stop the engine immediately and allow the pump to cool before priming.

PRIMING WATER FILLER CAP

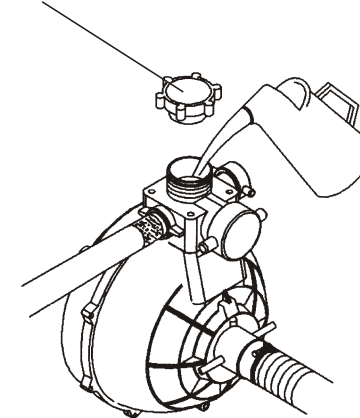

5.STARTING THE ENGINE

- 1.Open the fuel valve.
- 2.Set the engine governor lever at START position.

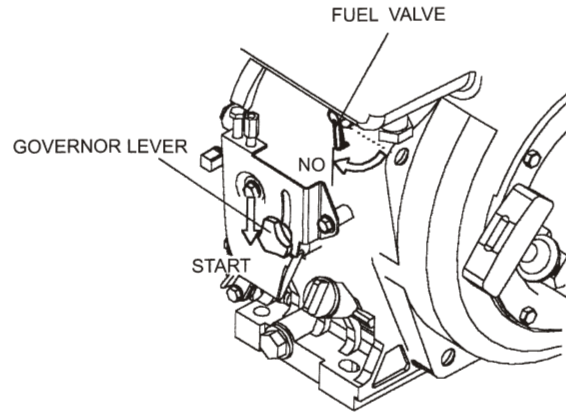

- 3.Pull the starter grip until you feel resistance,then return it back gently
- 4.Move the decompression handle to the no compression position. After the diesel engine started, decompression handle will return back automatically.

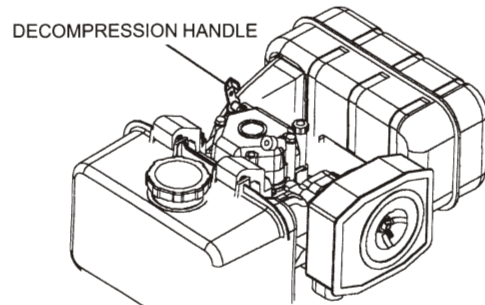

- 5.Pull the starter grip until you feel resistance,then pull briskly.
- 6.In the cold days, when it is difficult to start the diesel engine, screw off the refueling bolt in the cylinder cover and fill in 2 ml engine oil.

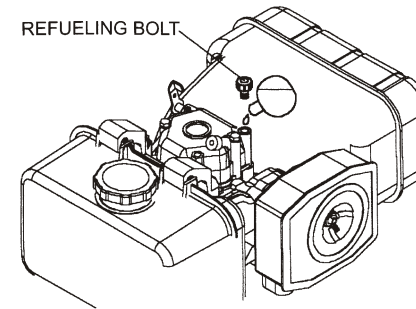

- 5.Hold the housing of the pump securely and pull the starter grip lightly until you feel resistance, then pull briskly.



Do not allow the starter grip to engine snap back against the engine. Return it gently to prevent damaging the starter.



Always pull the starter grip briskly. If not pulled briskly, it will result in failing to start the engine.

